

MANUAL**Model: PPT 12/24-7V**

Solar Converters Inc. - Rev. D

Note: To allow for fuse changing the lid is removable. While the unit is weather tight, it is recommended that it not be mounted in direct rainfall. Under the solar panel is an ideal location. If it is mounted in direct rainfall, a small amount of silicone sealant needs to be added where the lid joins the body.

QUICK START:

While it is recommended that the manual be read in detail before operating this unit, for the experienced technician, this section describes a quick system set up.

Power Connections: PV - to BLACK #16 AWG Flying Lead
 Pump + to WHITE #16 AWG Flying Lead
 Pump - to BLUE #16 AWG Flying Lead

Signal Connections: 1) Float/dry Switch

Connect yellow #24 AWG wires to float/dry switch and PV-
 Connect such that the yellow wires connect to PV- when unit is to shut off.

2) Panel Operating Voltage selection,

if 12 V operation, DO NOT connect purple wires to anything

if 24 V operation (**72 Cell Panel**), connect purple #22 AWG wire to PV- (see section 3.1)

if 24 V operation (**60 Cell Panel**), connect brown #22 AWG wire to PV- (see section 3.1)

3) Pump Voltage selection,

if 12 V pump, do not connect small orange wire to anything

if 24 V pump, connect orange # 22 AWG wire to PV-

NOTE: By connecting the purple or brown #24 AWG to PV- but not the orange #24 AWG, the unit will power a 12 V motor @ 7 amps from 24 V panels with a voltage limit of 15 V on the motor.

Connect Last:

Ensure Pump is clear and safe to operate

Power Connection: PV + to RED #16 AWG Flying Lead

Warning Disconnect or disable power source when connecting to this unit. Follow the appropriate wiring codes at all time. To be installed and operated by qualified personnel only. **No user serviceable parts inside.**

1.0 Specifications

This unit is a dual function 12/24 V unit on panel and output selected by the simple act of connecting it purple/brown and orange adjustment leads to PV-.

- Internal 10 Amp thermal resettable fuse
- Maximum power point tracking to optimize output power
- Efficiency: >94% over 20% charging load
- Transient protected - input and output
- Temperature range: -40 C to +60 C
- Start Current: 15 Amps for 10 seconds

Float/dry switch: On/off function is accomplished by connecting the yellow signal wires to PV- with a float/dry switch connection.

1.1 12 V Setting: See Section 3.1

Input Voltage: 0 - 24 DC volts PV Array, approx. 15 V nominal operating
Current: 0 - 6 DC amps nominal,

Output Voltage: N/A -defined by load and solar panel, Voltage limited to 15 V
Current: 0 - 7 DC amps nominal, surge to 15 amps

Connection: Power: max. AWG # 16 Fling Lead
Signal: max. AWG # 24 Flying Lead

1.2 24 V Setting: See Section 3.1

Input Voltage: 0 - 50 DC volts PV Array, approx. 30V nominal operating (72 Cell), 27V nominal operating (60 Cell)
Current: 0 - 6 amps nominal,

Output Voltage: N/A function of load and solar panel, voltage limited to 30V.
Current: 0 - 7 amps continuous, surge to 15 amps

Connection: Power: max. AWG # 16 Fling Lead
Signal: max. AWG # 24 Flying Lead

1.3 24 V panel to 12 V motor setting: See Section 3.1

Input Voltage: 0 - 50 DC volts PV Array, approx. 30V nominal operating (72 Cell), 27V nominal operating (60 Cell)
Current: 0 - 3 amps nominal,

Output Voltage: N/A function of load and solar panel, voltage limited to 15V.
Current: 0 - 7 amps continuous, surge to 15 amps

Connection: Power: max. AWG # 16 Fling Lead
Signal: max. AWG # 24 Flying Lead

2.0 Power Connections

2.1 Pump Connection

Using wire of sufficient amperage for the PUMP load connection #16 AWG or better connect the positive of the PUMP to the WHITE Power lead. Similarly connect the negative of the PUMP to the BLUE.

2.2 Input Power Connection

Using a wire of sufficient amperage for the input power (min. #16 AWG) connect the negative of the solar panel to the BLACK power lead. Connect the positive of the solar panel (do this as the last connection) to the RED Power Lead.

3.0 Signal Connections

3.1 Operating Voltage

This pump driver is a dual 12/24 volt pump driver. It is also capable of running from 72 cell 24V panels with approximately 36V nominal maximum power voltage rating, or 60 cell 24V panels with approximately 30V nominal maximum power voltage rating.

Note: 60 cell panels running a 24V pump will output approximately 25-27 volts depending on available power.

- 1) To operate at 12V: **DO NOT** connect the purple, brown or orange signal leads to PV-.
- 2) To operate at 24V (72 cell panel) : connect the purple and orange signal leads to PV-.
- 3) To operate at 24V (60 cell panel) : connect the purple and orange signal leads to PV-.
- 4) To operate 12 V motor from 24 V panels, connect purple (72 Cell panel) or brown (60 cell panel) signal lead to PV-, but not the orange.

3.2 Float Switch Operation

To turn the unit off, connect the yellow lead to a float/dry switch or similar device that connects the leads to PV- when it is desired to turn off the unit.

Application Notes

It is highly recommended an external fuse or over temperature device rated for the motor size be incorporated. The unit has an internal thermal resettable fusing rated at 10 amps that may be too high for the respective motor.

It is recommended that this unit be protected from direct rainfall. Under the solar panel is an ideal location. If it is required to work in direct rainfall, add a small amount of silicone sealant to the lid where it joins the case. This will make it more difficult to change the fuse if needed, but it will prevent water from entering the unit.

Basic hook up diagram. See section 3.1 for signal wire connections.

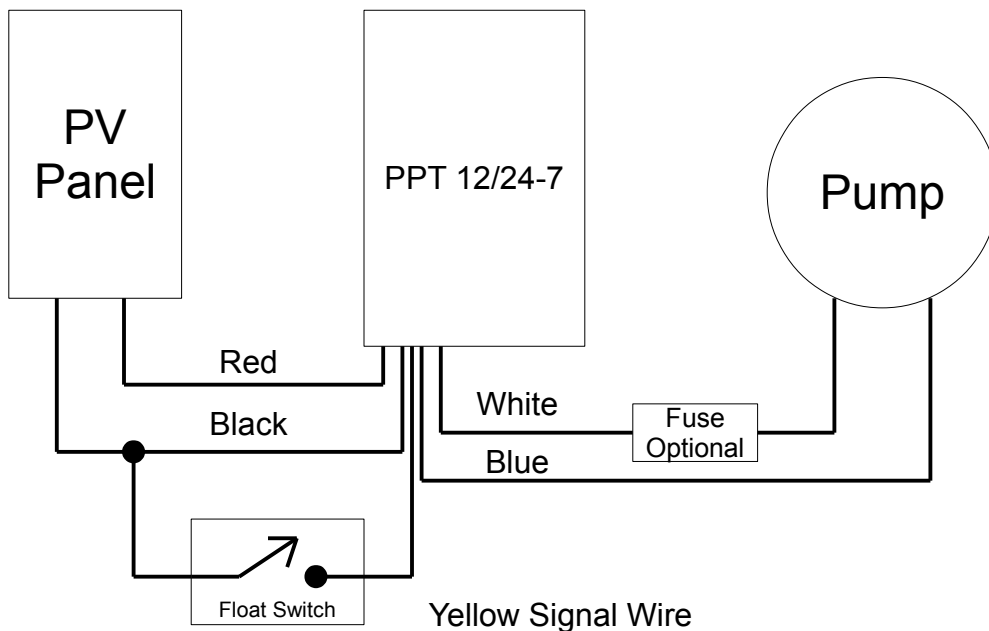

WARRANTY

The product is warranted to be free from defects in material and workmanship for a period of one (1) year from the date of purchase by a retail customer. The purchase date must be evidenced by a valid and original sales receipt. In lieu of sales receipt, factory will use code date on its label. Removal of the Solar Converters Inc. label or serial number will void the warranty.

Product liability, except where mandated by law, is limited to repair or replacement at the manufacturer's discretion. No specific claim of merchantability or use shall be assumed or implied beyond what is printed on the manufacturers printed literature. No liability shall exist from circumstances arising from the inability to use the product, or its inappropriateness for any specific purpose or actual use, or consequences thereof for any purpose. **It is the user's responsibility to determine the suitability of the product for any particular use.** Solar Converters Inc. shall not be liable for any damages or any kind including without limitation, special, incidental or consequential obligations and liabilities of Solar Converters Inc. and the remedies of Buyer set forth herein shall be Solar Converters Inc. sole and exclusive liability.

Failure to provide a safe and correct installation, safe operation, or care for the product will void the warranty. Personal safety, and compatibility with any other equipment is the ultimate responsibility of the end user. Any returned product that shows significant evidence of abuse may not be covered by this warranty. Installation must be performed by a person with qualification to insure safe and effective operation and the installation thereof certifies that the installer has the technical qualifications to do so.

Solar Converters Inc. cannot guarantee the compatibility of its products with other components used in conjunction with Solar Converters Inc. products, including, but not limited to, solar modules, batteries, and system interconnects, and such loads as inverters, transmitters and other loads which produce "noise" or electromagnetic interference, in excess of the levels to which Solar Converters Inc. products are compatible. Solar Converters Inc. shall not assume responsibility for any damages to any system components used in conjunction with Solar Converters Inc. products nor for claims for personal injury or property damage resulting from the use of Solar Converters Inc. products or the improper operation thereof or consequential damages arising from the products or use of the products.

The warranties set forth herein are Solar Converters Inc. sole and exclusive warranties for or relating to the goods. Seller neither makes nor assumes any warranty or merchantability, any warranty fitness for any particular purpose, or any other warranty of any kind, express, implied or statutory. Solar Converters Inc. neither assumes nor authorizes any person or entity to assume for it any other liability or obligation in connection with the sale or use of the goods, and there are no oral agreements or warranties collateral to or affecting the sale of the goods.

WARRANTY CLAIM PROCEDURE

In the event of product failure, follow this warranty claim procedure.

1. Make sure the problem you are having is actually due to the suspected product and not some other part of the system. You may call technical support for advanced troubleshooting assistance.
2. If you determine that a Solar Converters Inc. product is actually defective, describe on paper, in detail the exact nature of the failure.
3. The product must be accompanied by proof of the date of purchase satisfactory to Solar Converters Inc.
4. Return the product and description to the business office address, along with your address and a daytime phone number. Purchasers must prepay all delivery costs or shipping charges as well as any other charges encountered, in shipping any defective Solar Converters Inc. product under this warranty policy. **No shipment will be accepted Freight Collect.**
5. Any return shipment from Solar Converters Inc. will be via Canada Post. Foreign shipments will ship best way. Special shipping arrangements are available at the customer's expense.